



SKL 863 Wheel Loader

Power and state-of-the-art engineering

Operating weight 8.1 t
Engine output 74 kW (100 HP)
Bucket capacities 1.40-2.40 m³



SKL 863 - The machine illustrated may include non-standard equipment



Technical data

Engine

Manufacturer	Perkins
Type	4-cylinder turbocharged diesel engine
Combustion	4-stroke cycle, direct fuel injection
Displacement	4000 cm ³
Power rating acc. to ISO / TR 14396 (DIN 70020) EEC Euronorm 1 at 2200 rpm	74 kW (100 HP)
Cooling system	Water

Electrical system

Nominal voltage	12 V
Battery	12 V / 105 Ah / 450 A

Power transmission

Hydrostatic drive with perfected automatic driving function. Automatic adjustment of drawbar pull and speed. Infinitely variable speed control forward and reverse. 4-wheel drive from reduction gear on rear axle via propeller shaft to front axle. 2 speed ranges:

"Low"	0-6.5 km/h
"High"	0-20 km/h
High-speed version (optional):	
"Low"	0-6.0 / 0-19 km/h
"High"	0-12 / 0-36 km/h

Axles

Front: Rigid planetary final drive axle, slip-type differential.
Rear: Oscillating planetary final drive axle, with integrated reduction gear. Slip-type differential.
Oscillation ± 12 deg.

Tires

Standard	15.5 R 25 GP2 GoodYear
----------	------------------------

Brakes

Service brake: Hydraulically actuated center-mounted drum brake, acting on all 4 wheels via 4-wheel drive.
Auxiliary brake: Hydrostatic drive provides dynamic braking.
Parking brake: Mechanically actuated drum brake on front axle.

Steering

Articulated, fully hydraulic via priority valve, quick and easy steering even at engine idle-running speed.
Total steering angle 80 deg.

Fluid capacities

Fuel tank	143 l
Hydraulic system (includes tank)	100 l

Hydraulic system

Max. pump capacity	90.2 l/min
Working pressure	250 bar
Control unit: Hydraulic valve with 3 control circuits, single, four-way control lever (multi-function lever) for lift and dump cylinders with integrated travel direction selector switch. Float position in control circuit "Lowering", electro-hydraulically operated. Dump cylinder as patented cylinder with double end rod for quick loading and unloading.	

Loader frame

Parallel kinematics and integrated hydraulic quick-attach system.	
General-purpose bucket acc. to ISO 7546	1.40 m ³
Lift capacity at ground level acc. to ISO 8313	82,680 N
Ripping force at bucket edge acc. to ISO 8313	66,950 N

Operating data, standard equipment

Operating weight acc. to ISO 6016	8100 kg
Tipping load, straight acc. to ISO 8313	5730 kg
Tipping load, articulated acc. to ISO 8313	5060 kg
Total length, bucket on ground	5973 mm
Total width	2200 mm
Turning radius at outside bucket edge, transport position	4900 mm
Wheel base	2460 mm
Total height up to cab	2960 mm

Fork lift attachment

Payload over the total lift & steering range	3000 (3250*) kg
Payload in transport position, approx. 300 mm above ground level, total steering range	3250 (3500*) kg
Width of fork carrier	1485 mm
Length pallet forks (140 x 50)	1120 mm
Stability factor on level and solid ground	1.25
Load center from fork attachment point	500 mm
Payload determined according to DIN 24 094 / ISO 8313.	

Cab

Removable, rubber-mounted full-vision steel cab, ROPS (acc. ISO 3471) and FOPS** (acc. ISO 3449) certified. Cab is equipped with two doors, level entry to cab, electric windshield wipers and washer, front and rear, tinted panoramic safety glass, sliding window, on left-hand side. Driver's seat with hydraulic cushioning and lap belt, weight-adjustable. Hot water cab heating with windshield defroster, front and rear. Tilt steering wheel.
Noise emission ambient L_{WA} 101 dB (A)
Measured in dynamic measuring cycle according to 2000/14/EC.

* with rear axle weights

** FOPS-approved only with skylight guard (optionally)

Dimensions

SKL 863 General-purpose bucket

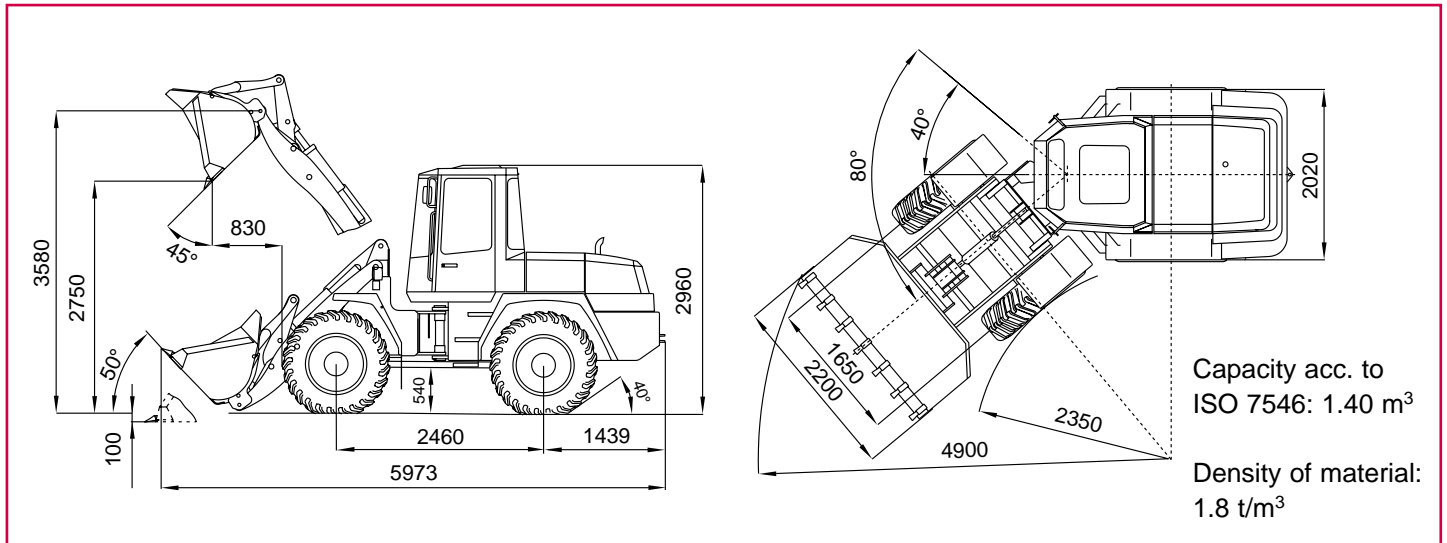

SKL 863 Fork lift attachment

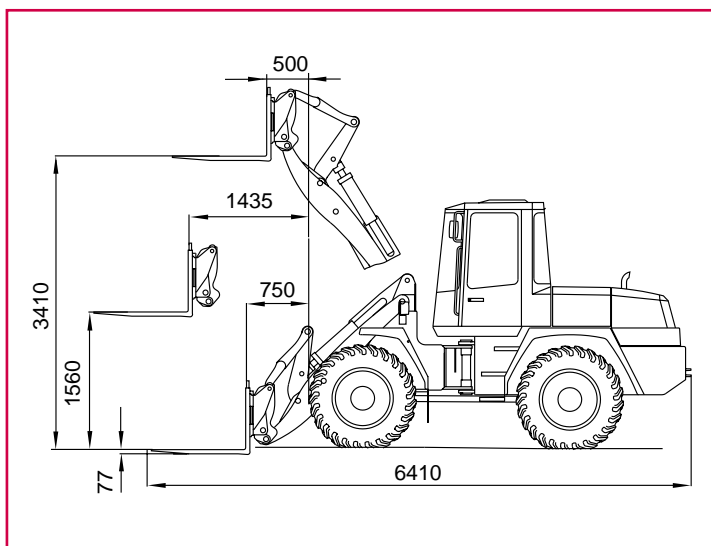

SKL 863 Multi-purpose bucket

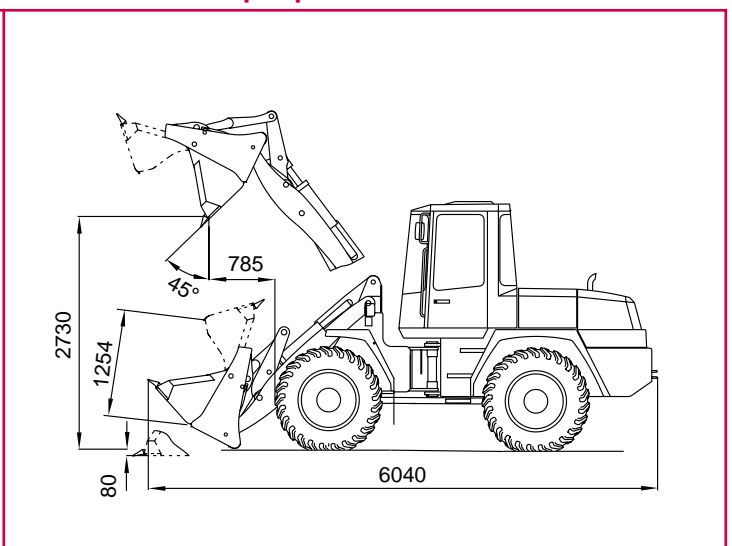

Payload over the total lift and steering range: 3000 (3250*) kg
 Payload in transport position: 3250 (3500*) kg
 * with rear axle weights

Capacity acc. to ISO 7546: 1.20 m³
 Density of material: 1.6 t/m³

Bucket type

	Capacity m ³	Density of M. t/m ³	Width mm	Dump height mm
General-purpose bucket	1.40	1.8	2200	2750
Earth bucket	1.55	1.6	2200	2690
Light-material bucket	1.80	1.2	2200	2640
Super light-material bucket	2.40	0.8	2500	2570
Multi-purpose bucket (4 in 1)	1.20	1.6	2200	2730
Side-dump bucket	1.00	1.8	2200	2560
High-tip bucket	1.20	1.2	2200	3930

Examples material densities:

Granite, sand (damp), gravel (damp): 1.8 t/m³
 Earth (damp), sand (dry), gravel (dry): 1.6 t/m³

Coal, slate: 1.2 t/m³
 Coke, wood chips (dry): 0.8 t/m³

Options and extras

Tires

Wide-base tires:

16/70-24 EM 10 PR MPT

455/70 R 24 SPT9 TL

19.5 LR 24 XM 27 TL

17.5-25 EM 12 PR

Non-standard tires available on request

Front attachments

Fork lift attachment w. forks 1120 mm long

Loading bucket*, earth bucket*, light-material bucket*, super light-material bucket, compost bucket, side-dump bucket, high-tip bucket, multi-purpose bucket*

Load hook , integrated in quick-mount hitch

Sweeper, snow blade

* Optionally with bolt-on cutting edge

Operator's stand

Air-cushioned comfort seat with orthopedic lumbar support, adjustable armrests and headrest

Independent diesel heating with timer

Height and tilt-adjustable steering wheel

Special versions without driver's cab available on request

Diesel engine – Optional equipment

Diesel exhaust cleaner

Catalyst

Alternative fuels available on request

Cab – Optional equipment

FOPS-skylight guard

Sliding window, integrated in right-hand door

Working floodlight, front

Working floodlight, rear

Yellow beacon

Intermittent windshield wiper

Pressurized cab

Air conditioning

Further options

High-speed travel version (36 km/h)

Filling with biodegradable hydraulic oil / Ester Base VI 68

Electrical tank refilling pump

Bucket ride control

Outlet for hydraulic hand-held hammer

Back-up alarm for reverse travel

Special creep speed versions available on request

Immobilizer

Rear axle weights

Hydraulic piping for 3rd control valve on lift frame including quick couplings (required for hydraulically operated attachments)

Pilot-controlled hose-rupture safety valves for lift and tilt cylinders

Lift height limitation

Automatic bucket return positioner

Further attachments available on request

Subject to change without further notice