



SKL 824 Wheel Loader

Power and state-of-
the-art engineering

Operating weight 3.9 t
Engine output 37 kW (50 HP)
Bucket capacities 0.65-1.00 m³



SKL 824 - The machine illustrated may include non-standard equipment



Technical data

Engine

Manufacturer	Deutz
Type	4-cylinder diesel engine
Combustion	4-stroke cycle, direct fuel injection
Displacement	3100 cm ³
Power rating acc. to ISO 9249 (DIN 70020) at 2300 rpm	37 kW (50 HP)
Cooling system	external oil cooling

Electrical system

Nominal voltage	12 V
Battery	12 V / 74 Ah / 400 A

Power transmission

Hydrostatic drive, closed circuit, independent from loader hydraulics. Automatic adjustment of drawbar pull and speed. Hydraulic motor power shift providing two speed ranges. Infinitely variable speed control forward and reverse. 4-wheel drive from reduction gear on rear axle via cardan shaft to front axle. 2 speed ranges:

"Low"	0-7 km/h
"High"	0-20 km/h
High-speed version (optional):	
"Low"	0-6,5 km/h / 0-18 km/h
"High"	0-13 km/h / 0-36 km/h
Drawbar pull	3022 daN

Axles

Front: Rigid planetary final drive axle, slip-type differential.
Rear: Oscillating (with cushioning) planetary final drive axle, with integrated reduction gear. Slip-type differential.
Oscillation ± 12 deg.

Tires

Standard	365/70 R 18 SPT 9 Dunlop
----------	--------------------------

Brakes

Service brake: hydraulically actuated center-mounted drum brake, acting on all 4 wheels via 4-wheel-drive.

Auxiliary brake: Hydrostatic drive provides dynamic braking.

Parking brake: Mechanically operated drum brake on front axle.

Steering

Articulated, with final position damping on both sides, fully hydraulic through load-sensing priority valve, quick and easy steering even at engine idle-running speed.

Total steering angle	80 deg.
----------------------	---------

Fluid capacities

Fuel tank	75 l
Hydraulic system (includes tank)	49 l

Hydraulic system

Max. pump capacity	41 l/min
Working pressure	250 bar
Control unit: Proportional hydraulic valve with 3 control circuits and high-speed valve for tilting; single, four-way lever (multi-function lever) for lift and dump cylinders with integrated travel direction selector switch and switch for additional control circuit. Float position in control circuit "Lowering", electro-hydraulically operated. Additional control circuit incl. quick couplers and continuous operation function provided as standard.	

Loader installation

Loader installation with true parallel linkage and integrated mechanical (optionally hydraulic) quick-attach system.

General-purpose bucket acc. to ISO 7546	0,65 m ³
Lift capacity at ground level acc. to ISO 8313	33.000 N
Breakout force at bucket edge acc. ISO 8313	37.000 N

Operating data, standard equipment

Operating weight acc. to ISO 6016	3900 kg
Tipping load, straight acc. to ISO 8313	2750 kg
Tipping load, articulated acc. to ISO 8313	2475 kg
Total length, bucket on ground	4780 mm
Total width	1700 mm
Turning radius outside bucket edge, transport position	3870 mm

Fork lift attachment

Payload over the total lift and steering range 1550 (1650*) kg	
Payload in transport position, approx. 300 mm above ground level, total steering range	1900* kg
Width of fork carrier	1240 mm
Length pallet forks (100 x 40 mm)	900 mm
Stability factor on level and solid ground	1.25

Cab

Rubber-mounted full-vision steel cab, ROPS (to ISO 3471) and FOPS** (to ISO 3449) certified.

Cab featuring two doors, level entry to cab, easy-to-be-cleaned cab floor; intermittent electric windshield wipers and washer, front and rear, tinted panoramic safety glass, sliding window on left-hand side. Driver's seat with hydraulic cushioning and lap belt (to ISO 7096 / ISO 6683), weight-adjustable. Cab heating with 3-setting heater fan (choice fresh air - recirculating air) and windshield defroster, front and rear. Tilt steering wheel. Radio and air conditioning pre-installation. 2 front working floodlights.

Noise emission ambient L _{WA}	99 dB (A)
Measured in dynamic measuring cycle acc. to 2000/14/EC.	

* with rear axle weights

** FOPS-approved only with skylight guard (optionally)

Dimensions

SKL 824 General-purpose bucket

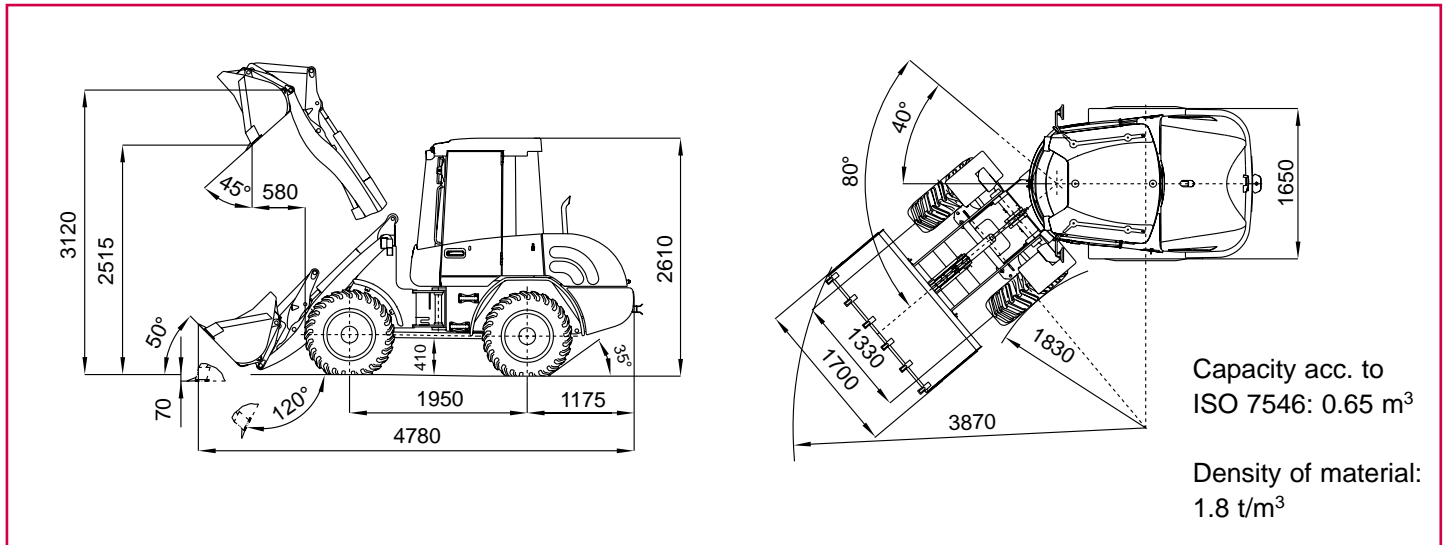

SKL 824 Fork lift attachment

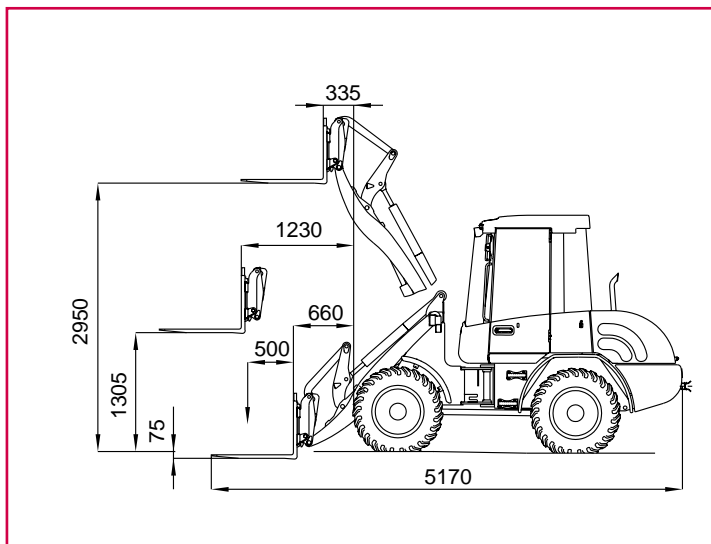

Payload over the total lift and steering range: 1550 (1650*) kg
Payload in transport position: 1900* kg
* with rear axle weights

SKL 824 Multi-purpose bucket

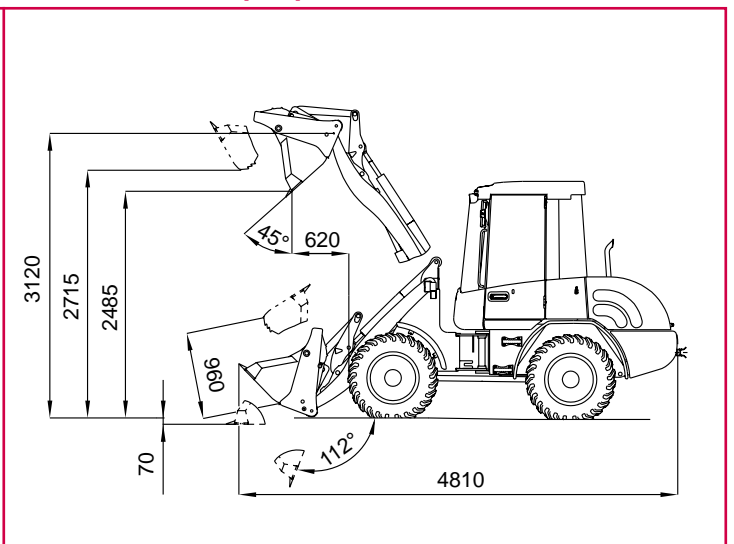

Capacity acc. to ISO 7546: 0.60 m³
Density of material: 1.6 t/m³

Bucket type

General-purpose bucket
Earth bucket
Light-material bucket
Super light-material bucket
Multi-purpose bucket (4 in 1)
Side-dump bucket
High-tip bucket

	Capacity m ³	Density of M. t/m ³	Width mm	Dump height mm
General-purpose bucket	0.65	1.8	1700	2515
Earth bucket	0.72	1.6	1700	2455
Light-material bucket	0.80	1.2	1700	2420
Super light-material bucket	1.00	0.8	1850	2380
Multi-purpose bucket (4 in 1)	0.60	1.6	1700	2485
Side-dump bucket	0.50	1.8	1750	2480
High-tip bucket	0.65	1.2	1850	3390

Examples material densities:

Granite, sand (damp), gravel (damp): 1.8 t/m³
Earth (damp), sand (dry), gravel (dry): 1.6 t/m³

Coal, slate: 1.2 t/m³
Coke, wood chips (dry): 0.8 t/m³

Options and extras

Tires

335/80 R 18 XM 27 TL Michelin

365/70 R 18 MPT 70 E Conti

Non-standard tires available on request

Front attachments

Fork lift attachment with forks (100 x 40 mm) 900 mm long

Fork lift attachment with forks (100 x 45 mm) 1120 mm long
(Payload reduced by approx. 30 kg)

General-purpose bucket *, earth bucket *, light-material bucket, side-dump bucket, high-tip bucket, multi-purpose bucket *

Load hook attachable on pallet forks

Load hook integrated in quick-attach system

Sweeper, snow blade

* optionally with bolt-on cutting edge

Quick-attach system

Hydraulically actuated

Operator's stand

Air-cushioned driver's seat with orthopedic lumbar support, adjustable armrests and headrest

Independent diesel heating with timer

Height and tilt-adjustable steering wheel

Fire extinguisher

Diesel engine - Optional equipment

Diesel exhaust cleaner

Catalyst

RME-fuel - rape oil methyl ester (Observe instructions provided by engine manufacturer)

Cab - Optional equipment

FOPS-skylight guard

Sliding door window, right

Working floodlight, rear

Yellow beacon

Pressurized cab

Air-conditioning

Further options

High-speed travel option (36 km/h)

Filling with biodegradable hydraulic oil / Ester Base VI 68

Electrical tank refilling pump

Outlet for hydraulic hand-held hammer

Back-up alarm for reverse travel

Special crawling speed version available on request

Anti-theft device, Immobilizer

Rear axle weights

Quick couplers (Flat-Face) for 3rd control circuit on lift frame

Pilot-controlled hose-rupture safety valves for lift and tilt cylinders

Further attachments available on request

Subject to change without further notice